

P4 Language Tutorial

Slides: <http://p4.elte.hu/tutorials/>

Instructors: Sándor Laki, Peter Vörös (ELTE)

Questions: info@p4.elte.hu or lakis@elte.hu

Software Setup

- Download VM or copy from one of the USB sticks distributed in the room
- Import VM into VirtualBox or VMware Fusion
- Boot VM and login as user "p4" with passwd "p4"
- Open Terminal and `cd ~/tutorials`



Instructors



SANDOR Laki
ELTE Eötvös Loránd University
Budapest, Hungary
lakis@elte.hu



PETER Vörös
ELTE Eötvös Loránd University
Budapest, Hungary

Goals

- **Learn P4 Language basics**
 - Traditional applications
 - Novel applications
- **Learn P4 software tools**
 - P4 Compiler
 - BMv2
 - T4P4S
- **"Hands on" exercises**
- **T4P4S demo – high performance on x86 with DPDK support**



What is Data Plane Programming?

- Why program the Data Plane?

Software Defined Networking (SDN)

- **Main contributions**

- OpenFlow = standardized *protocol* to interact with switch
 - download flow table entries, query statistics, etc.
- OpenFlow = standardized *model*
 - match/action abstraction
- *Concept* of *logically* centralized control via a single entity (“SDN controller”)
 - Simplifies control plane

- **Issues**

- Data-plane protocol evolution requires changes to standards (12 → 40 OpenFlow match fields)
- Limited interoperability between vendors (OpenFlow / netconf / JSON / XML variants)
- Limited programmability

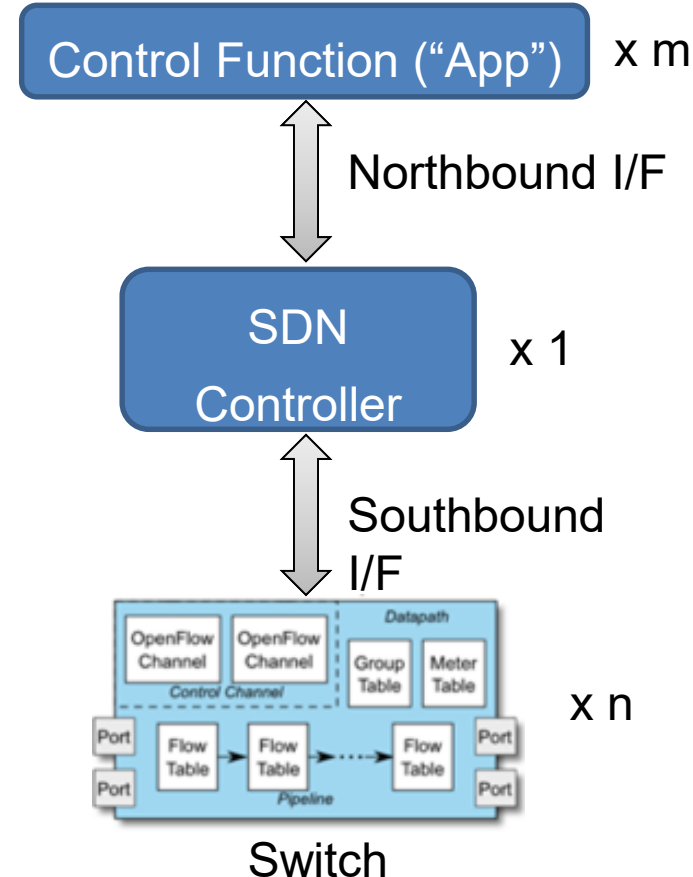

Status Quo: Bottom-up design

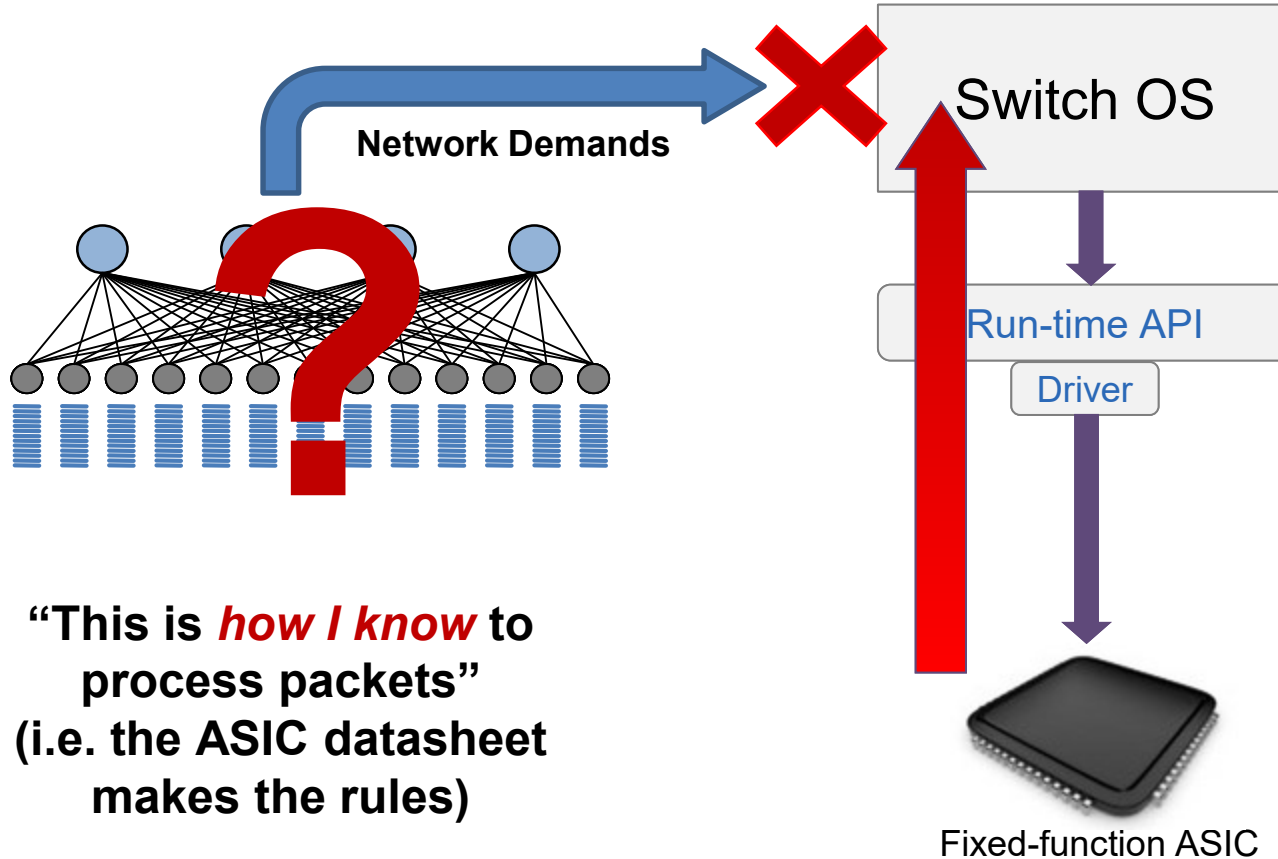

“This is *how I know* to process packets”
(i.e. the ASIC datasheet makes the rules)

Fixed-function ASIC

A Better Approach: Top-down design

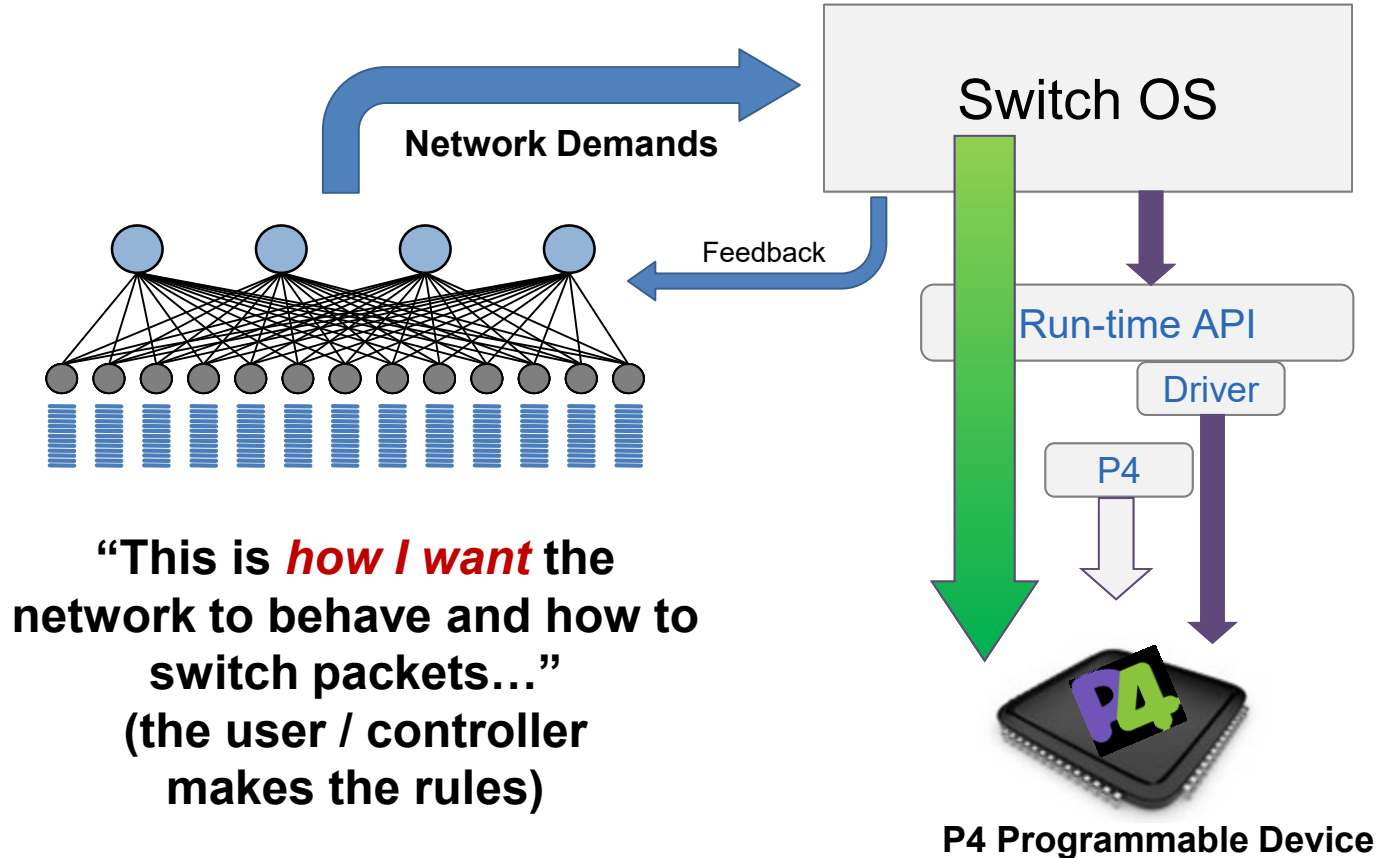

Benefits of Data Plane Programmability

- **New Features** – Add new protocols
- **Reduce complexity** – Remove unused protocols
- **Efficient use of resources** – flexible use of tables
- **Greater visibility** – New diagnostic techniques, telemetry, etc.
- **SW style development** – rapid design cycle, fast innovation, fix data plane bugs in the field
- **You keep your own ideas**

Think programming rather than protocols...



Programmable Network Devices

- **PISA: Flexible Match+Action ASICs**

- Intel Flexpipe, Cisco Doppler, Cavium (Xpliant), Barefoot Tofino, ...

- **NPU**

- EZchip, Netronome, ...

- **CPU**

- Open Vswitch, eBPF, DPDK, VPP...

- **FPGA**

- Xilinx, Altera, ...

These devices let us tell them how to process packets.



What can you do with P4?

- **Layer 4 Load Balancer – SilkRoad[1]**
- **Low Latency Congestion Control – NDP[2]**
- **In-band Network Telemetry – INT[3]**
- **In-Network caching and coordination – NetCache[4] / NetChain[5]**
- **Aggregation for MapReduce Applications [7]**
- **... and much more**

[1] Miao, Rui, et al. "SilkRoad: Making Stateful Layer-4 Load Balancing Fast and Cheap Using Switching ASICs." SIGCOMM, 2017.

[2] Handley, Mark, et al. "Re-architecting datacenter networks and stacks for low latency and high performance." SIGCOMM, 2017.

[3] Kim, Changhoon, et al. "In-band network telemetry via programmable dataplanes." SIGCOMM. 2015.

[4] Xin Jin et al. "NetCache: Balancing Key-Value Stores with Fast In-Network Caching." To appear at SOSP 2017

[5] Jin, Xin, et al. "NetChain: Scale-Free Sub-RTT Coordination." *NSDI*, 2018.

[6] Dang, Huynh Tu, et al. "NetPaxos: Consensus at network speed." SIGCOMM, 2015.

[7] Sapio, Amedeo, et al. "In-Network Computation is a Dumb Idea Whose Time Has Come." *Hot Topics in Networks*. ACM, 2017.



Brief History and Trivia

- **May 2013:** Initial idea and the name “P4”
- **July 2014:** First paper (SIGCOMM CCR)
- **Aug 2014:** First P4₁₄ Draft Specification (v0.9.8)
- **Sep 2014:** P4₁₄ Specification released (v1.0.0)
- **Jan 2015:** P4₁₄ v1.0.1
- **Mar 2015:** P4₁₄ v1.0.2
- **Nov 2016:** P4₁₄ v1.0.3
- **May 2017:** P4₁₄ v1.0.4

- **Apr 2016:** P4₁₆ – first commits
- **Dec 2016:** First P4₁₆ Draft Specification
- **May 2017:** P4₁₆ Specification released



P4_16 Data Plane Model



PISA: Protocol-Independent Switch Architecture

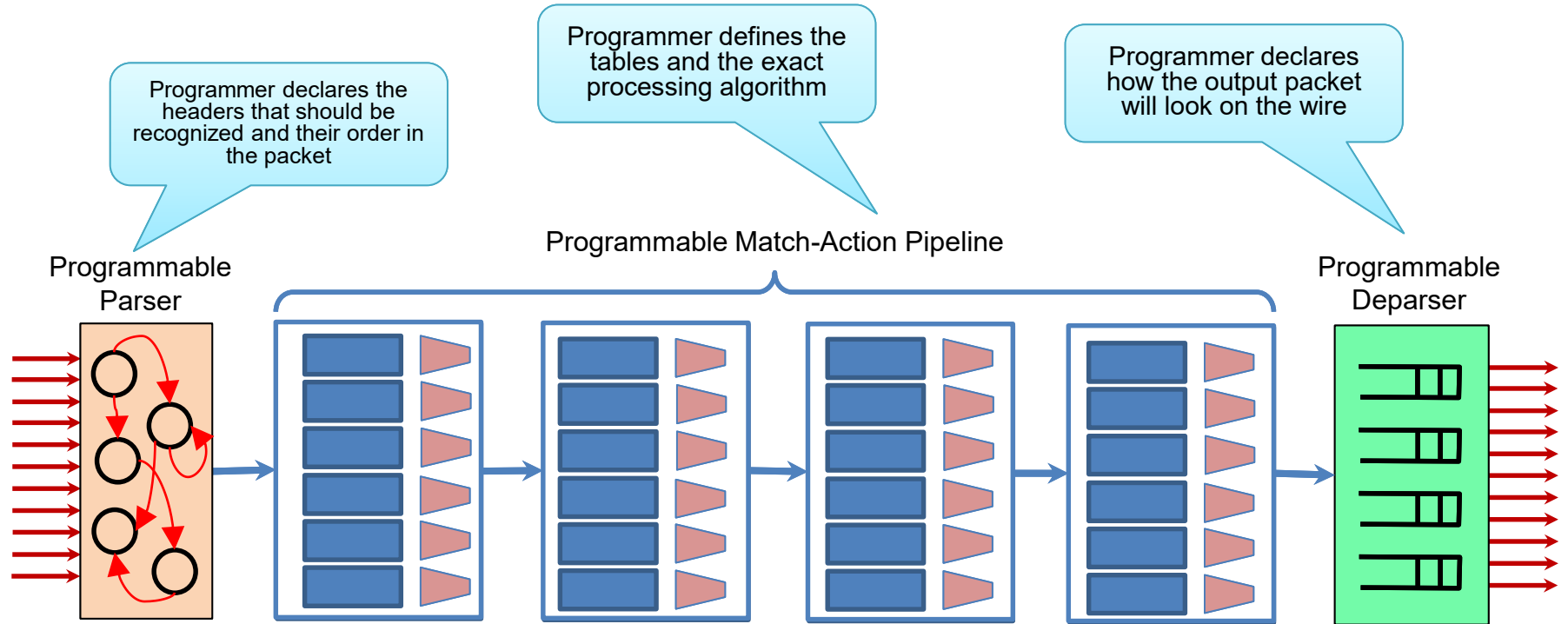

PISA in Action

- Packet is parsed into individual headers (parsed representation)
- Headers and intermediate results can be used for matching and actions
- Headers can be modified, added or removed
- Packet is deparsed (serialized)

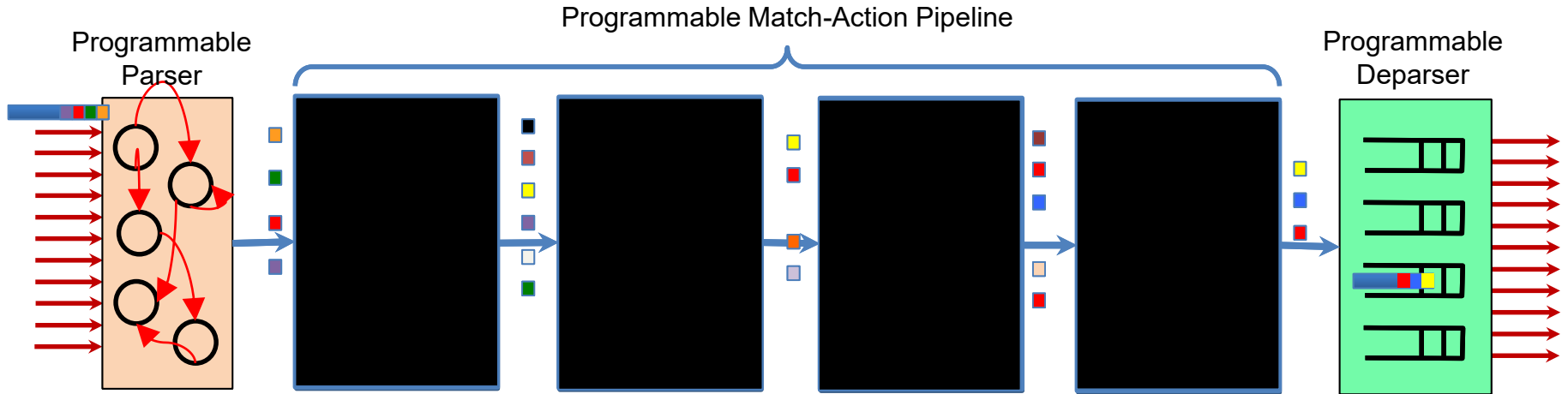

P4₁₆ Language Elements

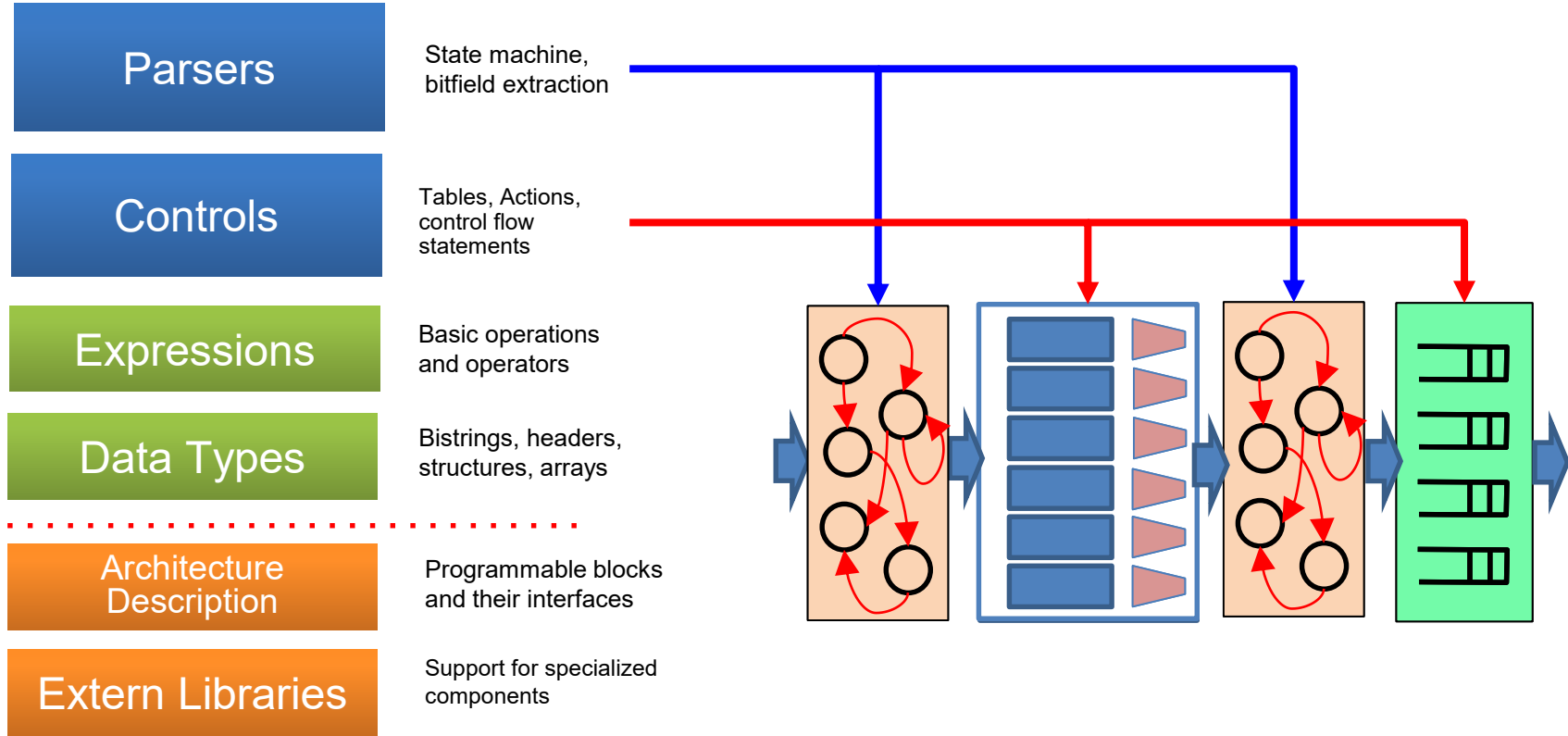

P4_16 Approach

Term	Explanation
P4 Target	An embodiment of a specific hardware implementation
P4 Architecture	Provides an interface to program a target via some set of P4-programmable components, externs, fixed components

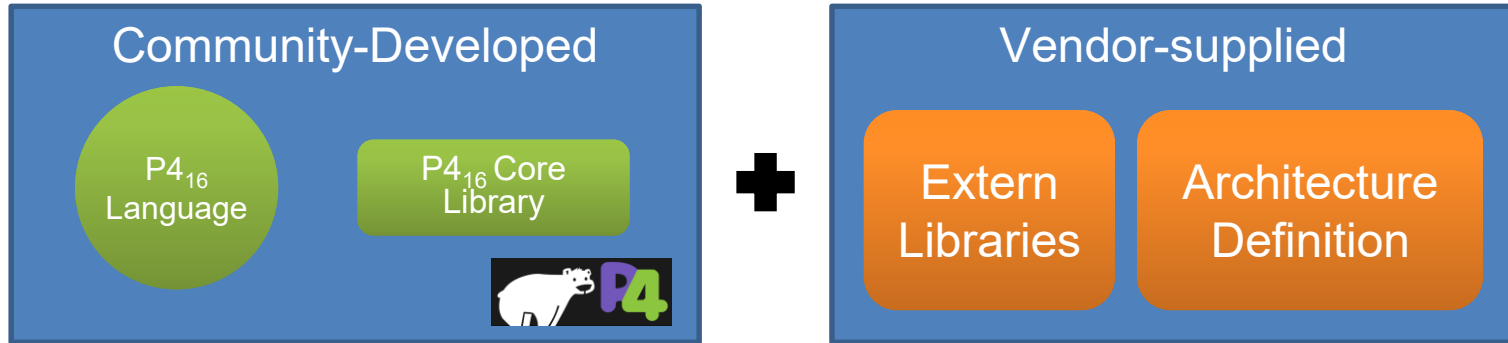

Example Architectures and Targets

V1Model

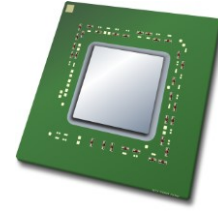
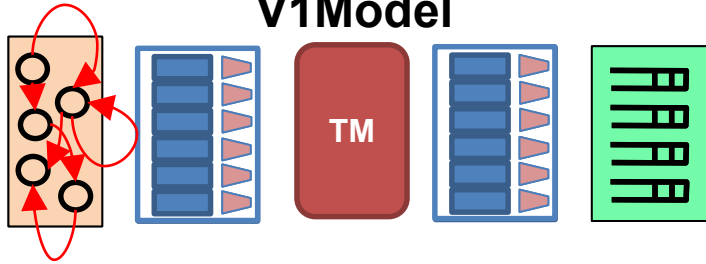

SimpleSumeSwitch

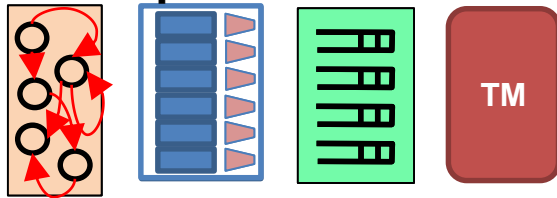

Portable Switch Architecture (PSA)

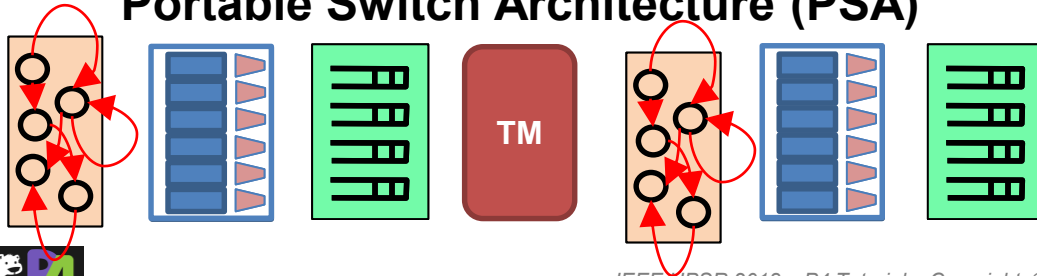

Anything

Programming a P4 Target

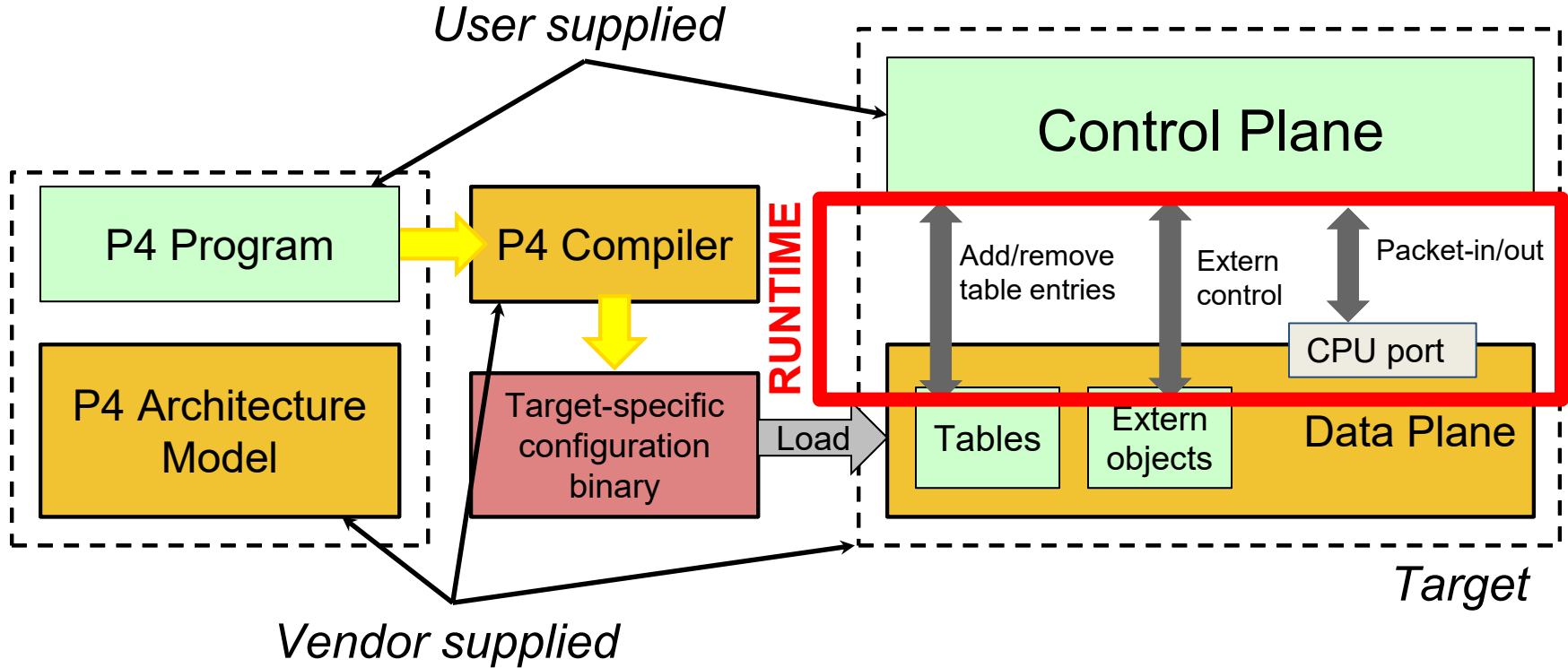

Lab 1: Basics



Before we start...

- **Install VM image (Look for instructor with USB sticks)**
- **Please make sure that your VM is up to date**
 - `$ cd ~/tutorials && git pull`
- **We'll be using several software tools pre-installed on the VM**
 - Bmv2: a P4 software switch
 - p4c: the reference P4 compiler
 - Mininet: a lightweight network emulation environment
- **Each directory contains a few scripts**
 - `$ make` : compiles P4 program, execute on Bmv2 in Mininet, populate tables
 - `*.py`: send and receive test packets in Mininet
- **Exercises**
 - Each example comes with an incomplete implementation; your job is to finish it!
 - Look for “TODOs” (or peek at the P4 code in `solution/` if you must)



V1Model Architecture

- Implemented on top of Bmv2's `simple_switch` target

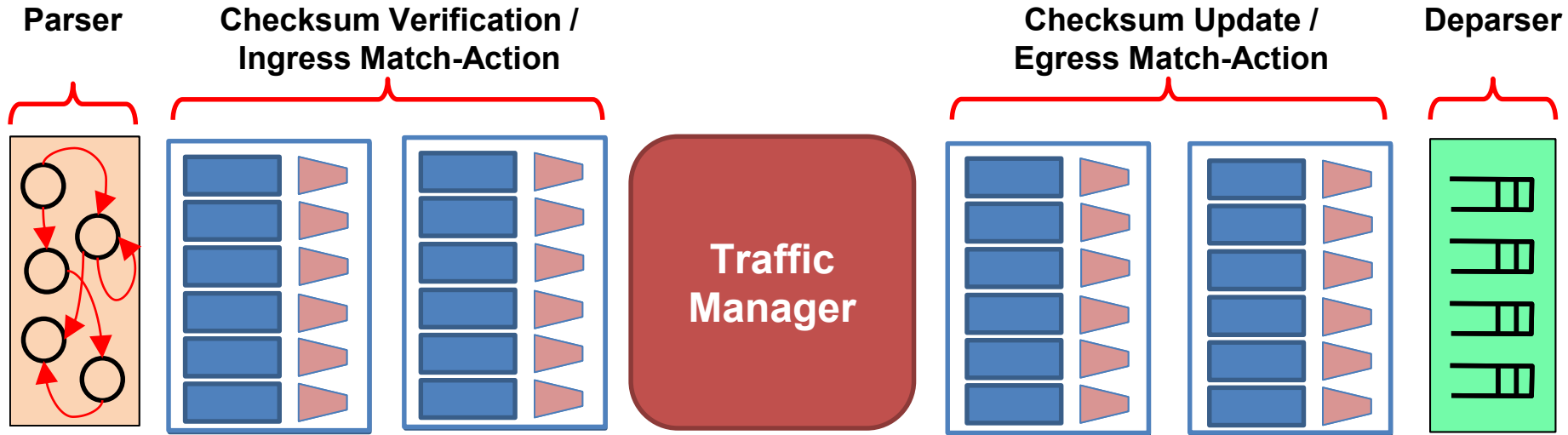

V1 Model Standard Metadata

```
struct standard_metadata_t {  
    bit<9>  ingress_port;  
    bit<9>  egress_spec;  
    bit<9>  egress_port;  
    bit<32> clone_spec;  
    bit<32> instance_type;  
    bit<1>  drop;  
    bit<16> recirculate_port;  
    bit<32> packet_length;  
    bit<32> enq_timestamp;  
    bit<19> enq_qdepth;  
    bit<32> deq_timedelta;  
    bit<19> deq_qdepth;  
    bit<48> ingress_global_timestamp;  
    bit<32> lf_field_list;  
    bit<16> mcast_grp;  
    bit<1>  resubmit_flag;  
    bit<16> egress_rid;  
    bit<1>  checksum_error;  
}
```

- **ingress_port** - the port on which the packet arrived
- **egress_spec** - the port to which the packet should be sent to
- **egress_port** - the port that the packet will be sent out of (read only in egress pipeline)



P4₁₆ Program Template (V1Model)

```
#include <core.p4>
#include <v1model.p4>
/* HEADERS */
struct metadata { ... }
struct headers {
    ethernet_t    ethernet;
    ipv4_t        ipv4;
}
/* PARSER */
parser MyParser(packet_in packet,
                out headers hdr,
                inout metadata meta,
                inout standard_metadata_t smeta) {
    ...
}
/* CHECKSUM VERIFICATION */
control MyVerifyChecksum(in headers hdr,
                        inout metadata meta) {
    ...
}
/* INGRESS PROCESSING */
control MyIngress(inout headers hdr,
                 inout metadata meta,
                 inout standard_metadata_t std_meta) {
    ...
}
```

```
/* EGRESS PROCESSING */
control MyEgress(inout headers hdr,
                inout metadata meta,
                inout standard_metadata_t std_meta) {
    ...
}
/* CHECKSUM UPDATE */
control MyComputeChecksum(inout headers hdr,
                         inout metadata meta) {
    ...
}
/* DEPARSER */
control MyDeparser(inout headers hdr,
                  inout metadata meta) {
    ...
}
/* SWITCH */
V1Switch(
    MyParser(),
    MyVerifyChecksum(),
    MyIngress(),
    MyEgress(),
    MyComputeChecksum(),
    MyDeparser()
) main;
```



P4₁₆ Hello World (V1Model)

```
#include <core.p4>
#include <v1model.p4>
struct metadata {}
struct headers {}

parser MyParser(packet_in packet,
  out headers hdr,
  inout metadata meta,
  inout standard_metadata_t standard_metadata) {

  state start { transition accept; }
}

control MyVerifyChecksum(inout headers hdr, inout metadata
meta) {  apply { }  }

control MyIngress(inout headers hdr,
  inout metadata meta,
  inout standard_metadata_t standard_metadata) {
apply {
  if (standard_metadata.ingress_port == 1) {
    standard_metadata.egress_spec = 2;
  } else if (standard_metadata.ingress_port == 2) {
    standard_metadata.egress_spec = 1;
  }
}
}
```

```
control MyEgress(inout headers hdr,
  inout metadata meta,
  inout standard_metadata_t standard_metadata) {
  apply { }
}

control MyComputeChecksum(inout headers hdr, inout metadata
meta) {
  apply { }
}

control MyDeparser(packet_out packet, in headers hdr) {
  apply { }
}

V1Switch(
  MyParser(),
  MyVerifyChecksum(),
  MyIngress(),
  MyEgress(),
  MyComputeChecksum(),
  MyDeparser()
) main;
```



P4₁₆ Hello World (V1Model)

```
#include <core.p4>
#include <v1model.p4>
struct metadata {}
struct headers {}

parser MyParser(packet_in packet, out headers hdr,
  inout metadata meta,
  inout standard_metadata_t standard_metadata) {
  state start { transition accept; }
}

control MyIngress(inout headers hdr, inout metadata meta,
  inout standard_metadata_t standard_metadata) {
  action set_egress_spec(bit<9> port) {
    standard_metadata.egress_spec = port;
  }
}

table forward {
  key = { standard_metadata.ingress_port: exact; }
  actions = {
    set_egress_spec;
    NoAction;
  }
  size = 1024;
  default_action = NoAction();
}

apply { forward.apply(); }
```

```
control MyEgress(inout headers hdr,
  inout metadata meta,
  inout standard_metadata_t standard_metadata) {
  apply { }
}
```

```
control MyVerifyChecksum(inout headers hdr, inout metadata
meta) { apply { } }
```

```
control MyComputeChecksum(inout headers hdr, inout metadata
meta) { apply { } }
```

```
control MyDeparser(packet_out packet, in headers hdr) {
  apply { }
}
```

```
V1Switch( MyParser(), MyVerifyChecksum(), MyIngress(),
MyEgress(), MyComputeChecksum(), MyDeparser() ) main;
```

Key	Action ID	Action Data
1	set_egress_spec ID	2
2	set_egress_spec ID	1



Running Example: Basic Forwarding

- We'll use a simple application as a running example—a basic router—to illustrate the main features of P4₁₆
- **Basic router functionality:**
 - Parse Ethernet and IPv4 headers from packet
 - Find destination in IPv4 routing table
 - Update source / destination MAC addresses
 - Decrement time-to-live (TTL) field
 - Set the egress port
 - Deparse headers back into a packet
- We've written some starter code for you (`basic.p4`) and implemented a static control plane



Basic Forwarding: Topology

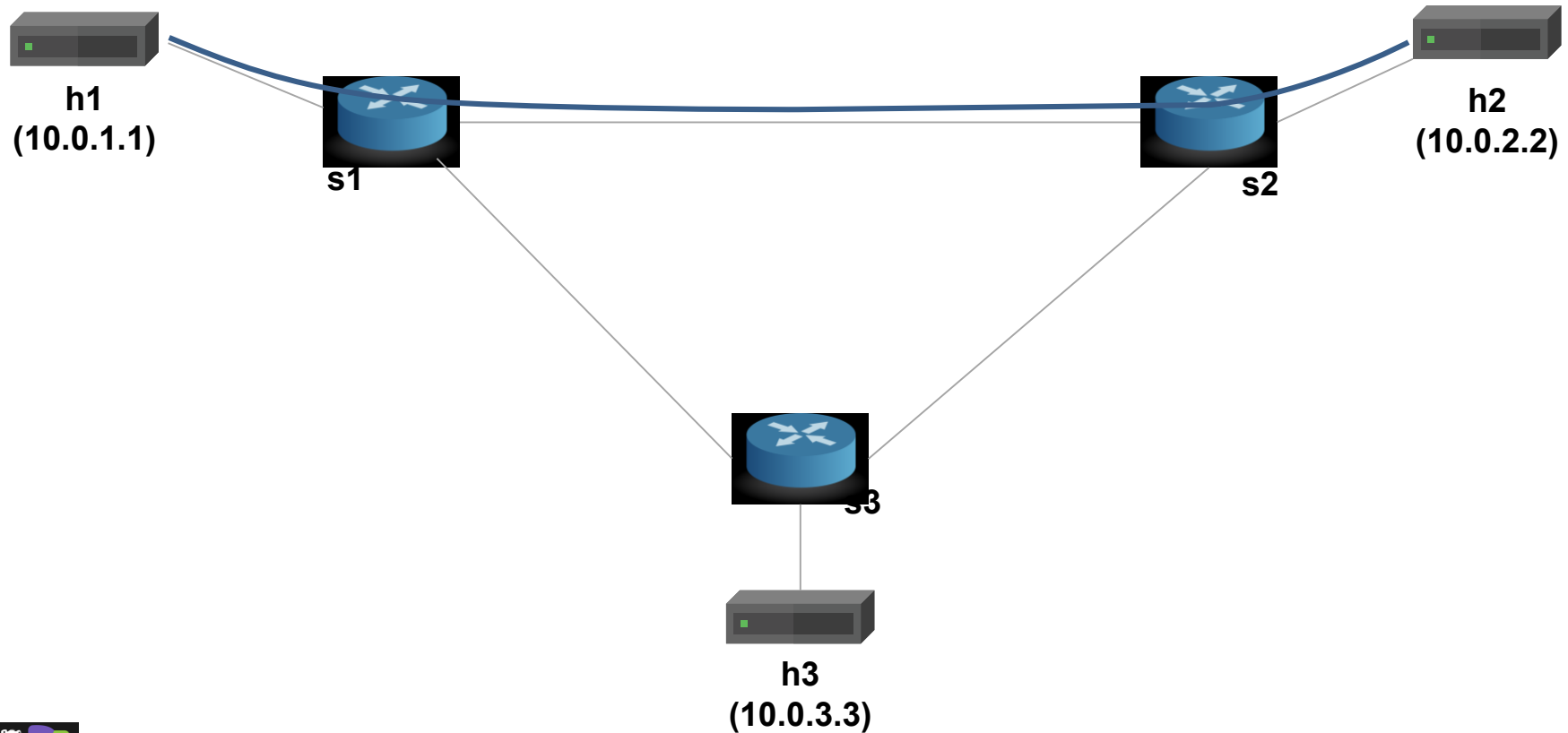

P4₁₆ Types (Basic and Header Types)

```
typedef bit<48> macAddr_t;
typedef bit<32> ip4Addr_t;
header ethernet_t {
    macAddr_t dstAddr;
    macAddr_t srcAddr;
    bit<16> etherType;
}
header ipv4_t {
    bit<4> version;
    bit<4> ihl;
    bit<8> diffserv;
    bit<16> totalLen;
    bit<16> identification;
    bit<3> flags;
    bit<13> fragOffset;
    bit<8> ttl;
    bit<8> protocol;
    bit<16> hdrChecksum;
    ip4Addr_t srcAddr;
    ip4Addr_t dstAddr;
}
```

Basic Types

- **bit<n>**: Unsigned integer (bitstring) of size n
- **bit** is the same as **bit<1>**
- **int<n>**: Signed integer of size n (≥ 2)
- **varbit<n>**: Variable-length bitstring

Header Types: Ordered collection of members

- Can contain **bit<n>**, **int<n>**, and **varbit<n>**
- Byte-aligned
- Can be valid or invalid
- Provides several operations to test and set validity bit: **isValid()**, **setValid()**, and **setInvalid()**

Typedef: Alternative name for a type



P4₁₆ Types (Other Types)

```
/* Architecture */
struct standard_metadata_t {
    bit<9>  ingress_port;
    bit<9>  egress_spec;
    bit<9>  egress_port;
    bit<32> clone_spec;
    bit<32> instance_type;
    bit<1>  drop;
    bit<16> recirculate_port;
    bit<32> packet_length;
    ...
}

/* User program */
struct metadata {
    ...
}
struct headers {
    ethernet_t  ethernet;
    ipv4_t      ipv4;
}
```

Other useful types

- **Struct:** Unordered collection of members (with no alignment restrictions)
- **Header Stack:** array of headers
- **Header Union:** one of several headers



P4₁₆ Parsers

- **Parsers are functions that map packets into headers and metadata, written in a state machine style**
- **Every parser has three predefined states**
 - start
 - accept
 - reject
- **Other states may be defined by the programmer**
- **In each state, execute zero or more statements, and then transition to another state (loops are OK)**

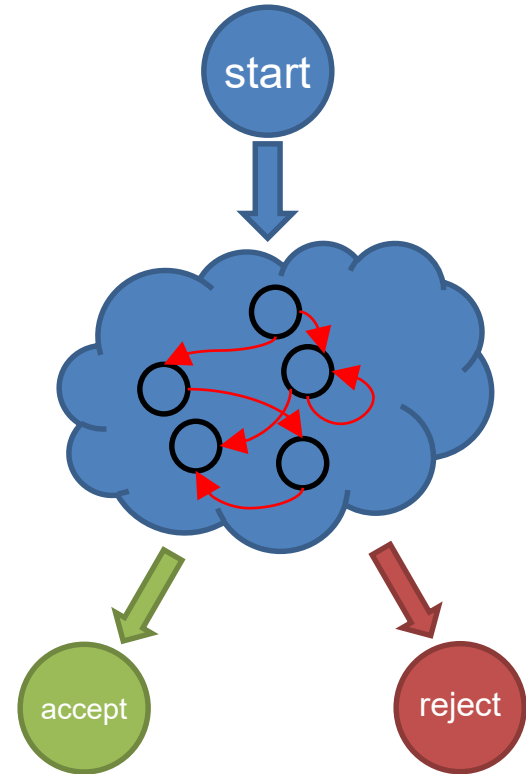

Parsers (V1Model)

```
/* From core.p4 */
extern packet_in {
  void extract<T>(out T hdr);
  void extract<T>(out T variableSizeHeader,
                 in bit<32> variableFieldSizeInBits);
  T lookahead<T>();
  void advance(in bit<32> sizeInBits);
  bit<32> length();
}
/* User Program */
parser MyParser(packet_in packet,
               out headers hdr,
               inout metadata meta,
               inout standard_metadata_t std_meta) {

  state start {
    packet.extract(hdr.ethernet);
    transition accept;
  }
}
```

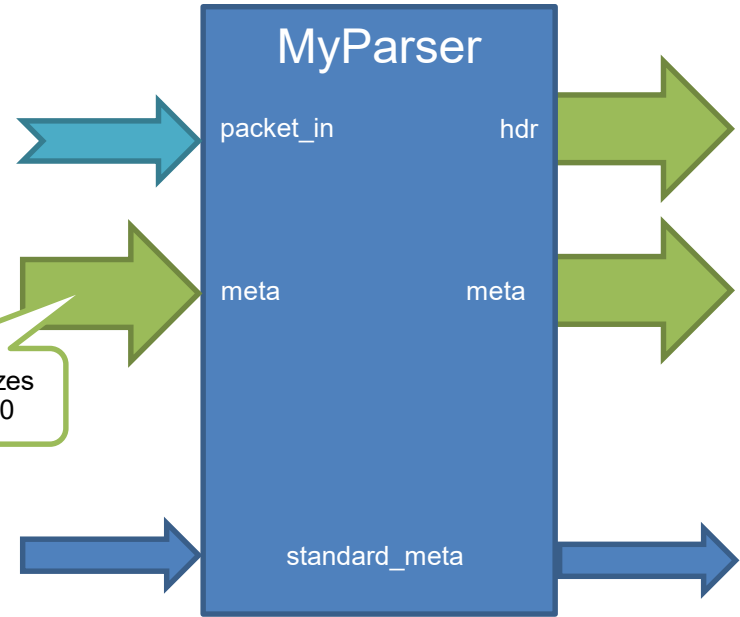

Select Statement

```
state start {
  transition parse_ethernet;
}

state parse_ethernet {
  packet.extract(hdr.ethernet);
  transition select(hdr.ethernet.etherType) {
    0x800: parse_ipv4;
    default: accept;
  }
}
```

P4₁₆ has a select statement that can be used to branch in a parser

Similar to case statements in C or Java, but without “fall-through behavior”—i.e., break statements are not needed

In parsers it is often necessary to branch based on some of the bits just parsed

For example, etherType determines the format of the rest of the packet

Match patterns can either be literals or simple computations such as masks



Coding Break



P4₁₆ Controls

- **Similar to C functions (without loops)**
- **Can declare variables, create tables, instantiate externs, etc.**
- **Functionality specified by code in `apply` statement**
- **Represent all kinds of processing that are expressible as DAG:**
 - Match-Action Pipelines
 - Deparsers
 - Additional forms of packet processing (updating checksums)
- **Interfaces with other blocks are governed by user- and architecture-specified types (typically headers and metadata)**



Example: Reflector (V1Model)

```
control MyIngress(inout headers hdr,  
                 inout metadata meta,  
                 inout standard_metadata_t std_meta) {  
  /* Declarations region */  
  bit<48> tmp;  
  
  apply {  
    /* Control Flow */  
    tmp = hdr.ethernet.dstAddr;  
    hdr.ethernet.dstAddr = hdr.ethernet.srcAddr;  
    hdr.ethernet.srcAddr = tmp;  
    std_meta.egress_spec = std_meta.ingress_port;  
  }  
}
```

Desired Behavior:

- **Swap source and destination MAC addresses**
- **Bounce the packet back out on the physical port that it came into the switch on**



Example: Simple Actions

```
control MyIngress(inout headers hdr,
                 inout metadata meta,
                 inout standard_metadata_t std_meta) {

    action swap_mac(inout bit<48> src,
                  inout bit<48> dst) {
        bit<48> tmp = src;
        src = dst;
        dst = tmp;
    }

    apply {
        swap_mac(hdr.ethernet.srcAddr,
                hdr.ethernet.dstAddr);
        std_meta.egress_spec = std_meta.ingress_port;
    }
}
```

- **Very similar to C functions**
- **Can be declared inside a control or globally**
- **Parameters have type and direction**
- **Variables can be instantiated inside**
- **Many standard arithmetic and logical operations are supported**
 - +, -, *
 - ~, &, |, ^, >>, <<
 - ==, !=, >, >=, <, <=
 - No division/modulo
- **Non-standard operations:**
 - Bit-slicing: [m:l] (works as l-value too)
 - Bit Concatenation: ++



P4₁₆ Tables

- **The fundamental unit of a Match-Action Pipeline**

- Specifies what data to match on and match kind
- Specifies a list of *possible* actions
- Optionally specifies a number of table **properties**
 - Size
 - Default action
 - Static entries
 - etc.

- **Each table contains one or more entries (rules)**

- **An entry contains:**

- A specific key to match on
- A **single** action that is executed when a packet matches the entry
- Action data (possibly empty)



Tables: Match-Action Processing

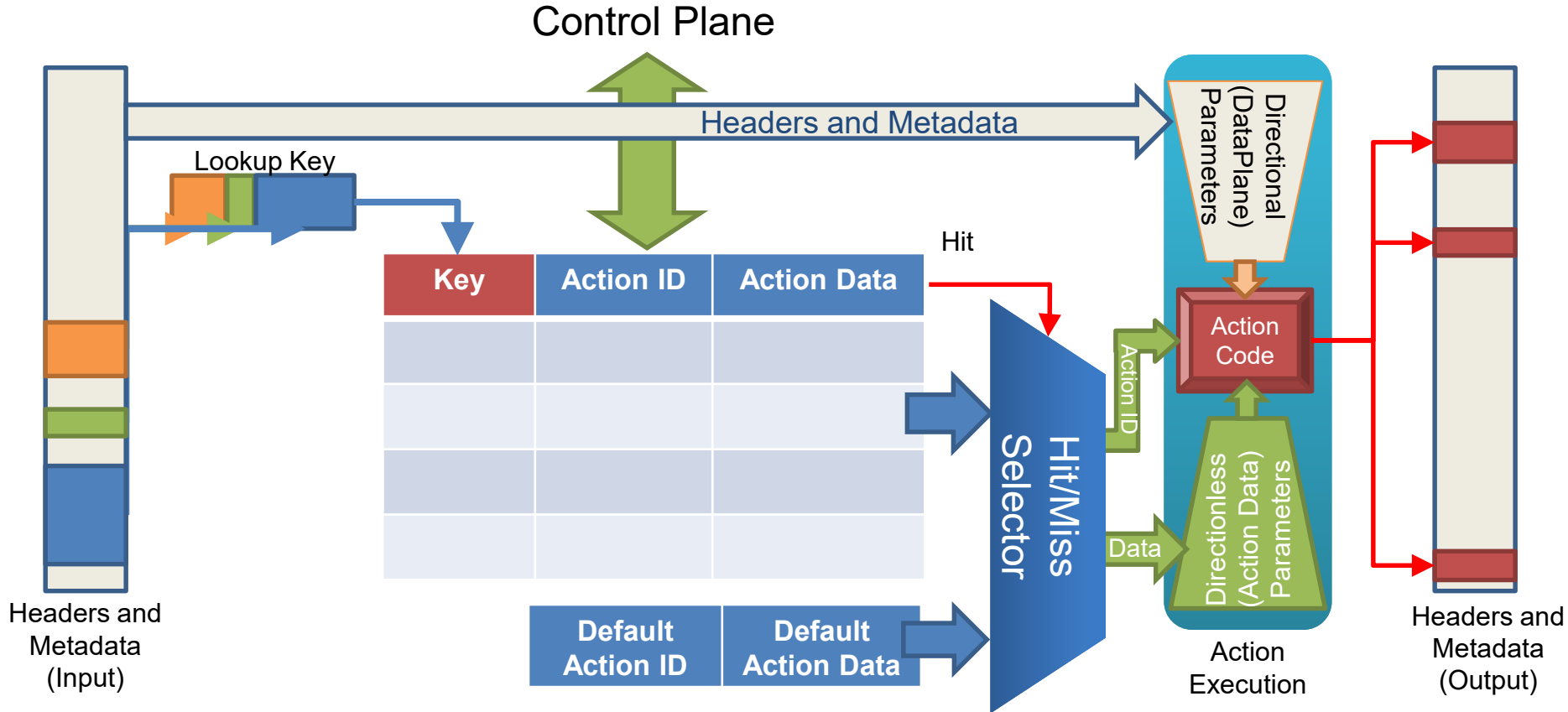

Example: IPv4_LPM Table

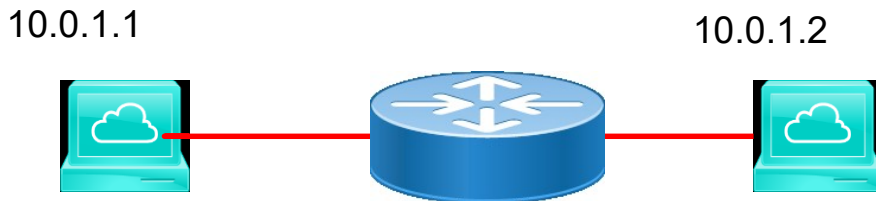

Key	Action	Action Data
10.0.1.1/32	ipv4_forward	dstAddr=00:00:00:00:01:01 port=1
10.0.1.2/32	drop	
*^	NoAction	

- **Data Plane (P4) Program**
 - Defines the format of the table
 - Key Fields
 - Actions
 - Action Data
 - Performs the lookup
 - Executes the chosen action
- **Control Plane (IP stack, Routing protocols)**
 - Populates table entries with specific information
 - Based on the configuration
 - Based on automatic discovery
 - Based on protocol calculations

IPv4_LPM Table

```
table ipv4_lpm {
    key = {
        hdr.ipv4.dstAddr: lpm;
    }
    actions = {
        ipv4_forward;
        drop;
        NoAction;
    }
    size = 1024;
    default_action = NoAction();
}
```

Match Kinds

```
/* core.p4 */  
match_kind {  
    exact,  
    ternary,  
    lpm  
}
```

```
/* v1model.p4 */  
match_kind {  
    range,  
    selector  
}
```

```
/* Some other architecture */  
match_kind {  
    regexp,  
    fuzzy  
}
```

- The type `match_kind` is special in P4
- The standard library (`core.p4`) defines three standard match kinds
 - Exact match
 - Ternary match
 - LPM match
- The architecture (`v1model.p4`) defines two additional match kinds:
 - range
 - selector
- Other architectures may define (and provide implementation for) additional match kinds



Defining Actions for L3 forwarding

```
/* core.p4 */  
action NoAction() {  
}  
  
/* basic.p4 */  
action drop() {  
    mark_to_drop();  
}  
  
/* basic.p4 */  
action ipv4_forward(macAddr_t dstAddr,  
                    bit<9> port) {  
    ...  
}
```

- **Actions can have two different types of parameters**
 - Directional (from the Data Plane)
 - Directionless (from the Control Plane)
- **Actions that are called directly:**
 - Only use directional parameters
- **Actions used in tables:**
 - Typically use directionless parameters
 - May sometimes use directional parameters too



Applying Tables in Controls

```
control MyIngress(inout headers hdr,  
                 inout metadata meta,  
                 inout standard_metadata_t standard_metadata) {  
    table ipv4_lpm {  
        ...  
    }  
    apply {  
        ...  
        ipv4_lpm.apply();  
        ...  
    }  
}
```

P4₁₆ Deparsing

```
/* From core.p4 */
extern packet_out {
    void emit<T>(in T hdr);
}

/* User Program */
control DeparserImpl(packet_out packet,
                     in headers hdr) {
    apply {
        ...
        packet.emit(hdr.ethernet);
        ...
    }
}
```

- **Assembles the headers back into a well-formed packet**
- **Expressed as a control function**
 - No need for another construct!
- **packet_out extern is defined in core.p4**: emit(hdr): serializes header if it is valid
- **Advantages:**
 - Makes deparsing explicit...
...but decouples from parsing



Coding Break



Basic Tunneling

- Add support for basic tunneling to the basic IP router
- Define a new header type (`myTunnel`) to encapsulate the IP packet
- `myTunnel` header includes:
 - `proto_id` : type of packet being encapsulated
 - `dst_id` : ID of destination host
- Modify the switch to perform routing using the `myTunnel` header

Basic Tunneling TODO List

- **Define myTunnel_t header type and add to headers struct**
- **Update parser**
- **Define myTunnel_forward action**
- **Define myTunnel_exact table**
- **Update table application logic in MyIngress apply statement**
- **Update deparser**
- **Adding forwarding rules**



Basic Forwarding: Topology

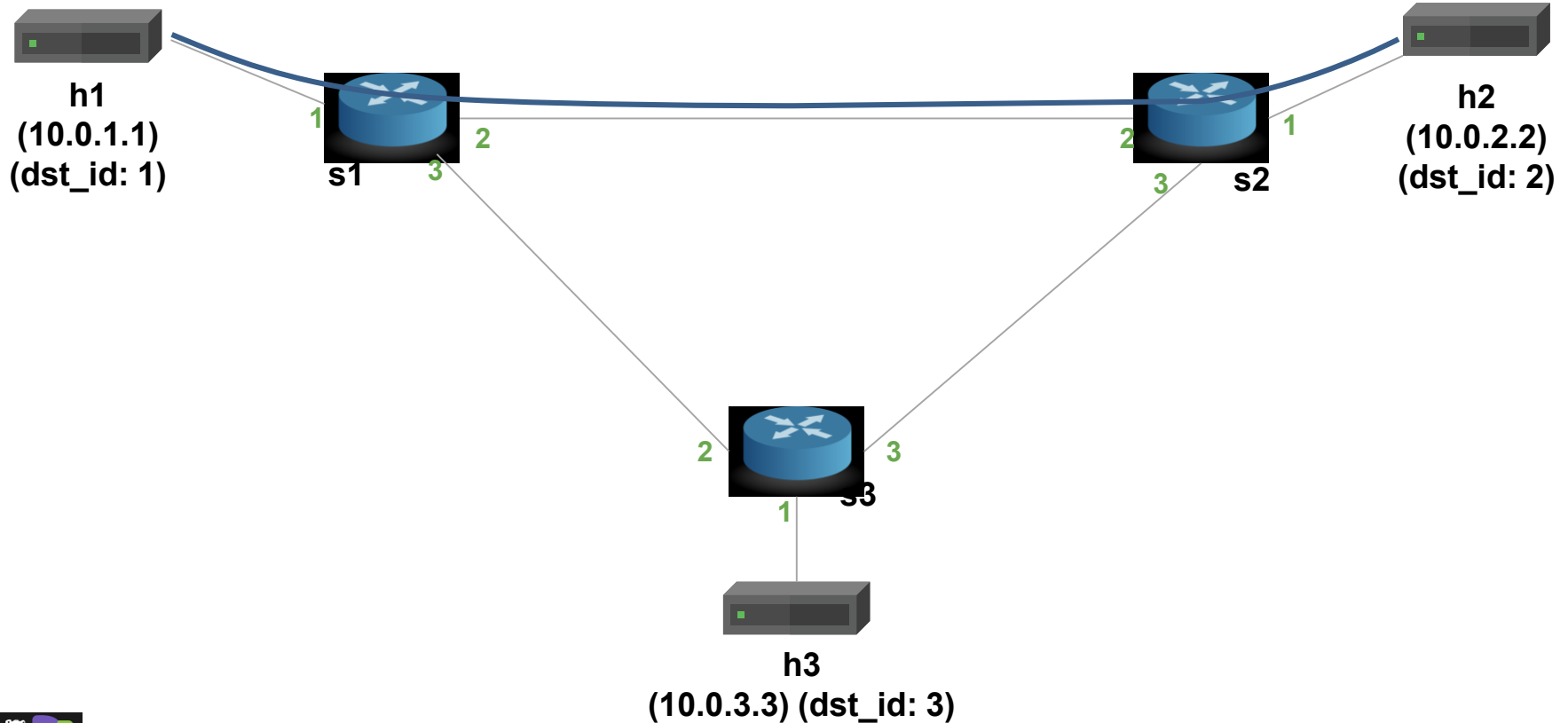

Coding Break



FAQs

- **Can I apply a table multiple times in my P4 Program?**
 - No (except via resubmit / recirculate)
- **Can I modify table entries from my P4 Program?**
 - No (except for direct counters)
- **What happens upon reaching the `reject` state of the parser?**
 - Architecture dependent
- **How much of the packet can I parse?**
 - Architecture dependent



Fin!



Lab 4: Advanced Behavior



Source Routing

2,3,2,2,1, {payload}

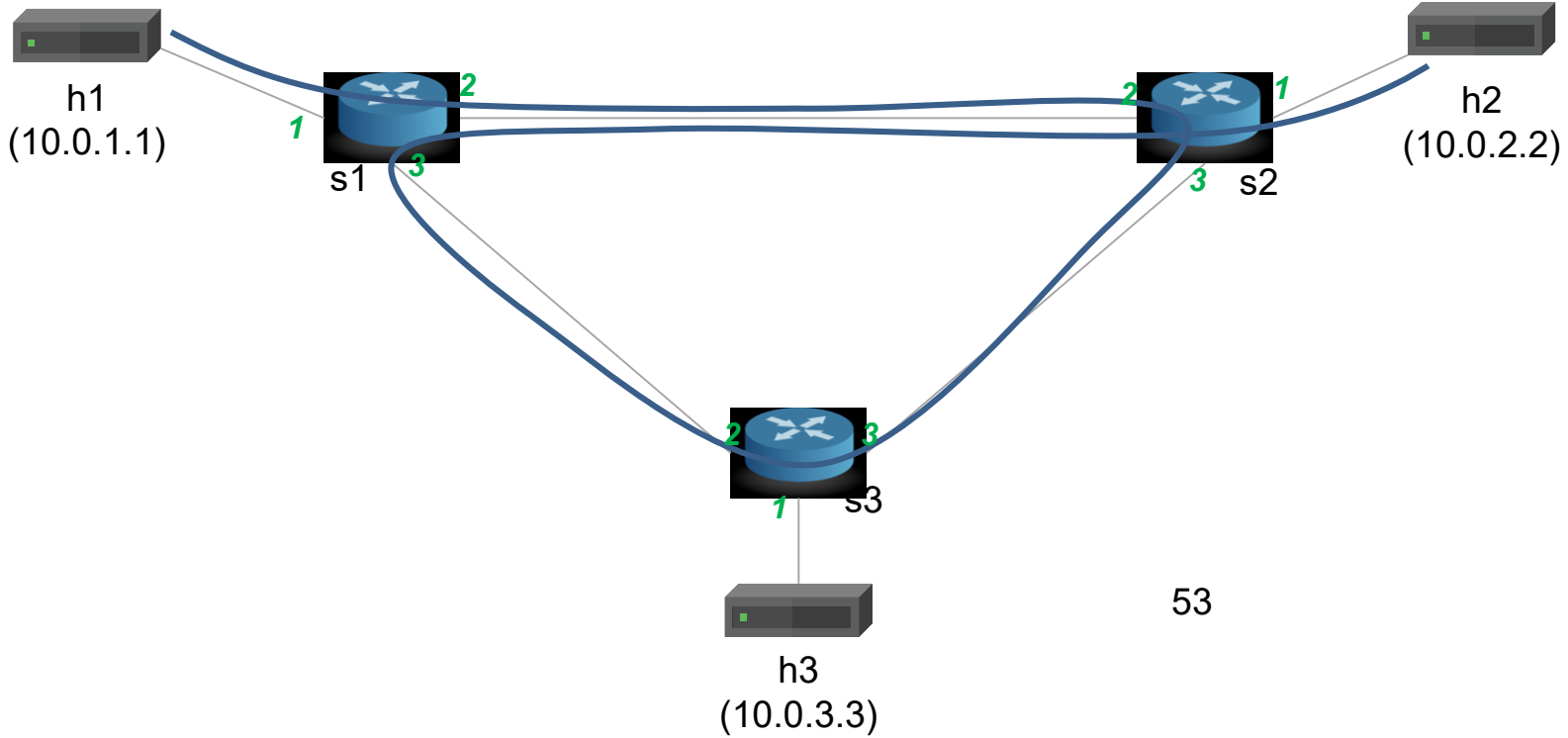

Source Routing: Packet Format

```
#define MAX_HOPS 9

const bit<16> TYPE_IPV4 = 0x800;
const bit<16> TYPE_SRCROUTING = 0x1234;

header srcRoute_t {
    bit<1>    bos;
    bit<15>  port;
}

struct headers {
    ethernet_t          ethernet;
    srcRoute_t[MAX_HOPS] srcRoutes;
    ipv4_t              ipv4;
}
```

- **Parse source routes only if etherType is 0x1234**
- **The special value bos == 1 indicates the “bottom of stack”**
- **Forward packets using source routes, and also decrement IPv4 TTL**
- **Drop the packet if source routes are not valid**
- **Hint: Use the next, pop_front primitives**
`packet.extract(hdr.srcRoutes.next)`
`hdr.srcRoutes.pop_front(1)`



Coding Break



Calculator

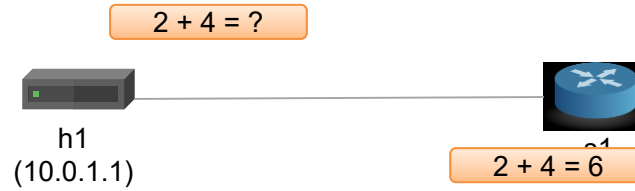

Calculator: Packet Format

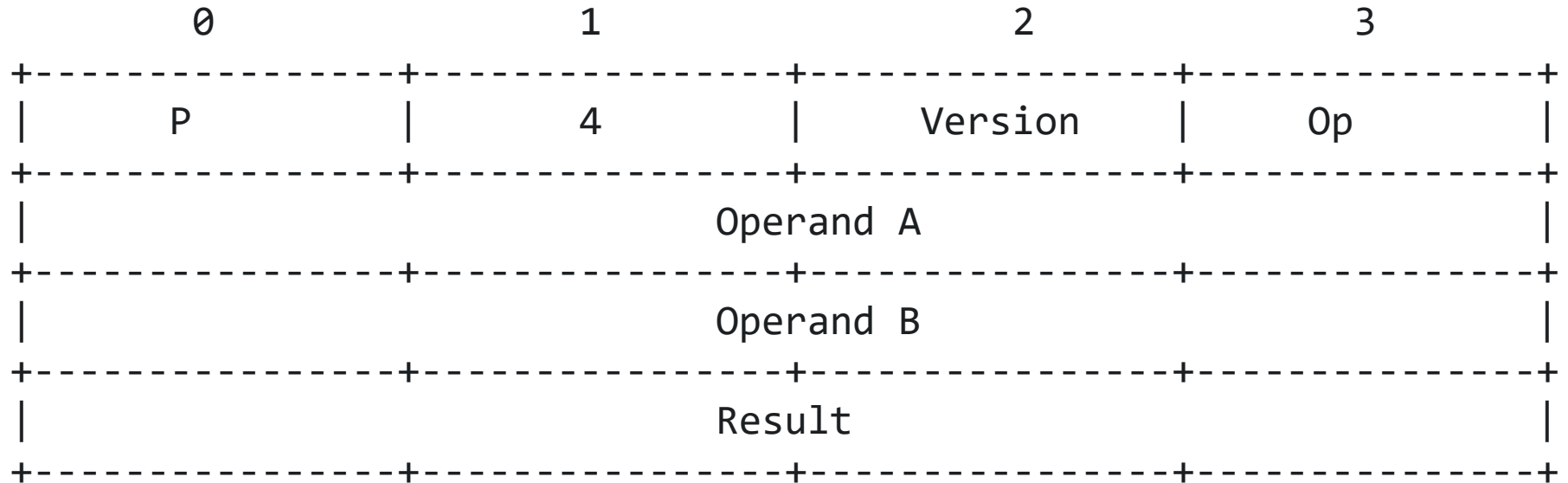

Table Initializers

```
table tbl {  
  key = { hdr.h.f : exact }  
  actions = { a1; a2; a3 }  
  entries = {  
    { 0x01 } : a1(1);  
    { 0x02 } : a1(2);  
    { _ } : NoAction();  
  }  
}
```

Can initialize tables with constant entries

Must fully specify the value of all action data, including values that are normally supplied by the control-plane

Hint: for the calculator, use a table that matches on the op-code

Coding Break



Why P4₁₆?

- **Clearly defined semantics**
 - You can describe what your data plane program is doing
- **Expressive**
 - Supports a wide range of architectures through standard methodology
- **High-level, Target-independent**
 - Uses conventional constructs
 - Compiler manages the resources and deals with the hardware
- **Type-safe**
 - Enforces good software design practices and eliminates “stupid” bugs
- **Agility**
 - High-speed networking devices become as flexible as any software
- **Insight**
 - Freely mixing packet headers and intermediate results



High performance P4 dataplane on x86

- **T4P4S-16**
- **Open source multi-target compiler for both P4-14 and P4-16**
 - DPDK, ODP, Linux (OpenWRT) back-ends
- **On GitHub**
 - <https://github.com/P4ELTE/t4p4s>
 - Choose „t4p4s-16” branch
- **Examples**
 - Portfwd, L2fwd, L3fwd, SMGW, BNG in „examples” folder



Goals of T4P4S

- **Extended data plane programmability**
 - P4 code as a high level abstraction
- **Support of different hardware targets**
 - CPUs, NPU, FPGA, etc.
- **Create a compiler that separates hardware dependent and independent parts**
 - Easily retargetable P4 compiler

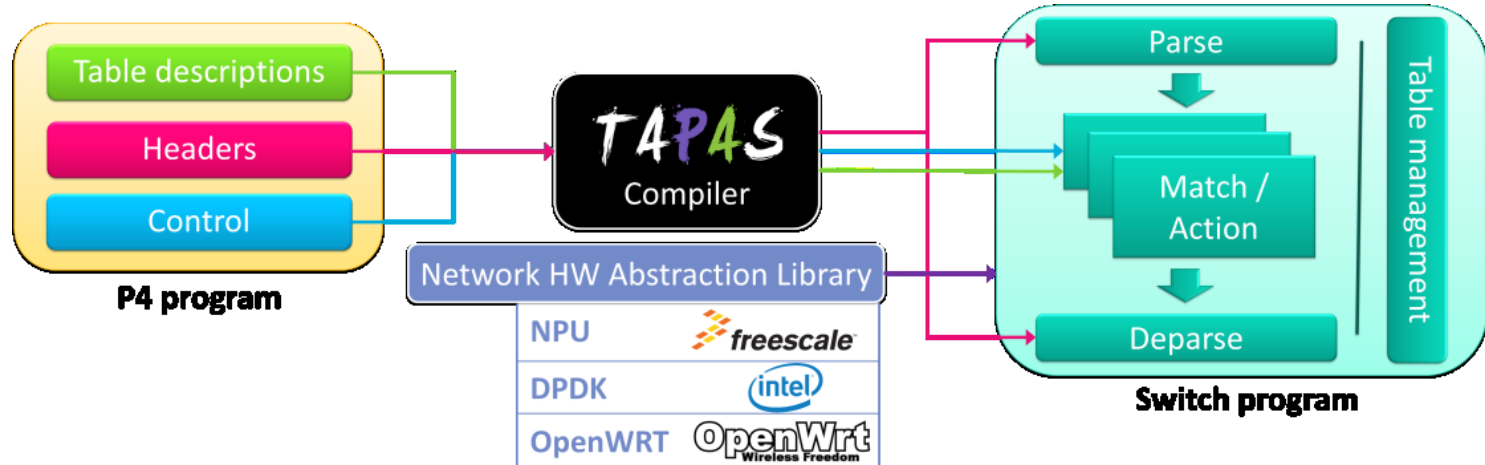

Multi-target Compiler Architecture for P4

1. Hardware-independent „Core”

- Using an Intermediate Representation (IR)
- Compiling IR to a hardware independent C code with NetHAL calls

2. Hardware-dependent „Network Hardware Abstraction Layer” (NetHAL)

- Implementing well primitives that fulfill the requirements of most hardware
- A static and thin library
- Written by a hardware expert (currently available for DPDK and ODP)

3. Switch program

- Compiled from the hardware-independent C code of the „Core” and the target-specific HAL
- Resulting in a hardware dependent switch program

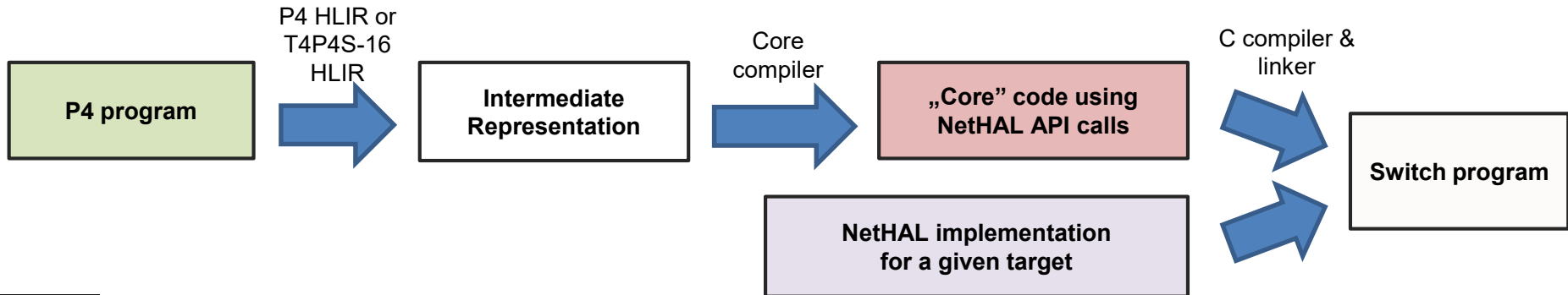

Multi-target Compiler Architecture for P4

• PROs

- Much simpler compiler
- Modularity = better maintainability
- Exchangeable NetHAL = re-targetable switch (without rewriting a single line of code)
- NetHAL is not affected by changes in the P4 program

• CONs

- Potentially lower performance
- Difficulties with protocol/hardware-dependent optimization
- Communication overhead between the components (C function calls)
- Too general vs too detailed NetHAL API

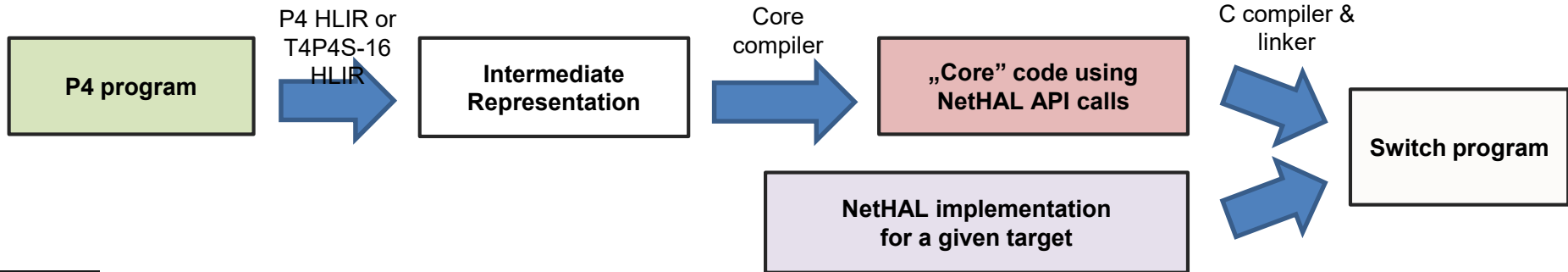

T4P4S performance demo – MGW use case

5G User Plane Function – Mobile Gateway

The mobile gateway pipeline represents a simplified 5G UPF that connects a set of mobile user equipments (UEs), located behind base stations (BSTs), to a set of public servers available on the Internet.

Mobile gateway processing steps per uplink/downlink packet:

Uplink:

- L2, L3 and L4 check (gateway MAC/IP and UDP port destination 2152)
- GTP decap, save TEID
- Rate limit per bearer (TEID)
- L3 routing towards the Internet + L2 fwd

Downlink:

- L2 and L3 check (check if destination IP is in the UE range)
- per user rate limiting
- GTP encap (set bearer in TEID)
- set destination IP of the base station of the UE
- L3 routing towards BSTs + L2 fwd

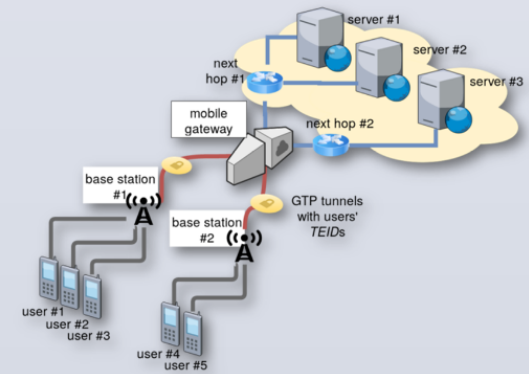
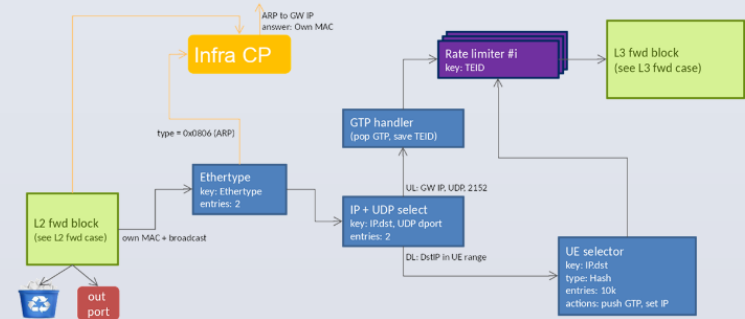

T4P4S performance demo – MGW use case



Downlink Performance

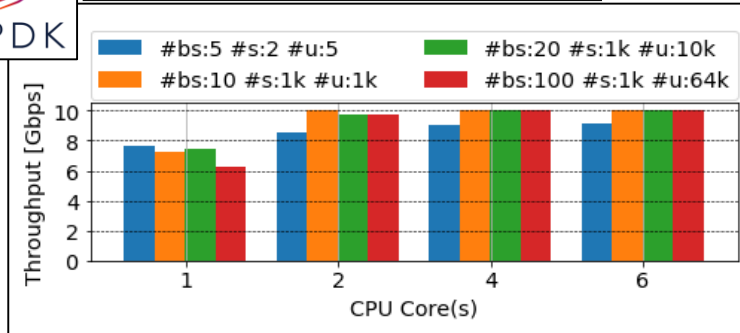

Demo setup

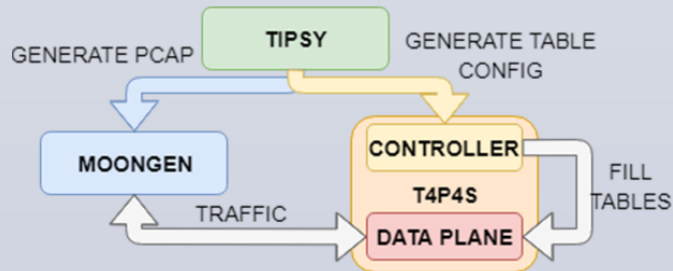

Small testbed deployed at Eötvös Loránd University with 2 nodes

- AMD Ryzen Threadripper 1900X
- Intel Corporation 82599ES 10-Gigabit Dual port NIC
- DPDK 18.02.01
- T4P4S (<https://github.com/P4ELTE/t4p4s>) T4P4S-16 branch
- TIPSY (<https://github.com/hsnlab/tipsy>)



Things we covered

- **The P4 "world view"**
 - Protocol-Independent Packet Processing
 - Language/Architecture Separation
 - If you can interface with it, it can be used
- **Key data types**
- **Constructs for packet parsing**
 - State machine-style programming
- **Constructs for packet processing**
 - Actions, tables and controls
- **Packet deparsing**
- **Architectures & Programs**



Things we didn't cover

- **Mechanisms for modularity**
 - Instantiating and invoking parsers or controls
- **Details of variable-length field processing**
 - Parsing and deparsing of options and TLVs
- **Architecture definition constructs**
 - How these “templated” definitions are created
- **Advanced features**
 - How to do learning, multicast, cloning, resubmitting
 - Header unions
- **Other architectures**
- **Control plane interface**



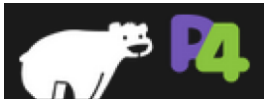

The P4 Language Consortium

- Consortium of academic and industry members
- Open source, evolving, domain-specific language
- Permissive Apache license, code on GitHub today
- Membership is free: contributions are welcome
- Independent, set up as a California nonprofit

Protocol Independent
P4 programs specify how a switch processes packets.

Target Independent
P4 is suitable for describing everything from high-performance forwarding ASICs to software switches.

Field Reconfigurable
P4 allows network engineers to change the way their switches process packets after they are deployed.

```
table routing {
  key = { ipv4.dstAddr : lpm; }
  actions = { drop; route; }
  size : 2048;
}
control ingress() {
  apply {
    routing.apply();
  }
}
```

TRY IT! GET THE CODE ON GITHUB





Contact: info@p4.elte.hu

The project has been supported by the European Union, co-financed by the European Fund. (EFOP-3.6.2-16-2017-00013).

